

## 61 Telescopic Forks

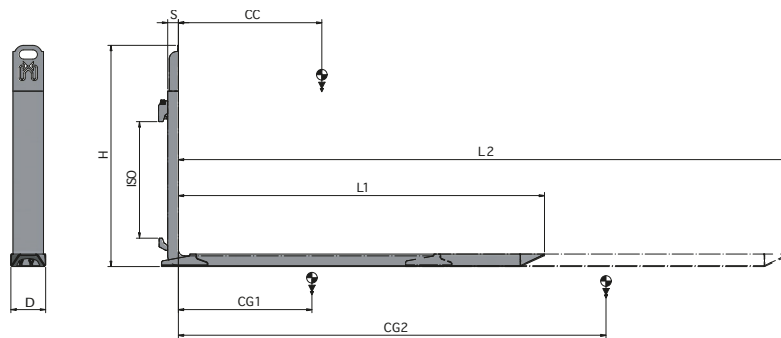

Hydraulic functions: 1 | Max working pressure: 175 Bar

### Features:

- Hydraulic attachments. • Handling of palletized goods in double depth. • Reduced dimensions to facilitate manoeuvres in confined spaces. • A single cylinder allows the use of smaller section forks and higher push/pull strength. • Flow divider to regulate the synchronism between the two forks. • Flow divider valve. • Stop-pallet.

### Special Equipment:

- Custom made Forks. • Custom made Stop-pallet with/without Load Backrests.

Article	Capacity per Pair	Load Centre of gravity	ISO	Fork Section		Height	Length		Thickness	Centre of Gravity		Weight
				N°	P (kg)		CC (mm)	2328		D (mm)	G (mm)	
53UFA2A150	1700	600	2a	128	41	725	1200	2000	35+5	360	498	119
53UFA2A143	1700	600	2a	128	41	725	1350	2350	35+5	428	608	128
53UFA2A139	2500	600	2a	133	58	725	1000	1650	53	349	481	151
53UFA2A133	2500	600	2a	133	58	725	1150	1950	53	402	560	163
53UFA2A126	2500	600	2a	133	58	725	1250	2150	53	447	629	174
53UFA2A119	2500	600	2a	133	58	725	1350	2350	53	493	699	183
53UKQ3A039	4500	600	3a	163	58	850	1150	1950	53	375	511	218
53UKQ3A028	4500	600	3a	163	58	850	1250	2150	53	418	575	232
53UKQ3A033	4500	600	3a	163	58	850	1350	2350	53	462	641	247

### Accessories on request

Hoses and Fitting Kit

Hoses and quick-release Couplings Kit

Hydraulic System Kit for mounting on Fork Positioners

Hydraulic System Kit with chain for mounting on Fork Positioners

Stop-pallet

Oil flow rate	
ISO	(L/min)
	↑ ↓
2	20
3	20

↑ Opening  
↓ Closing



Please refer to our catalogue for further Special Equipment