

340 PN Tyres Clamp

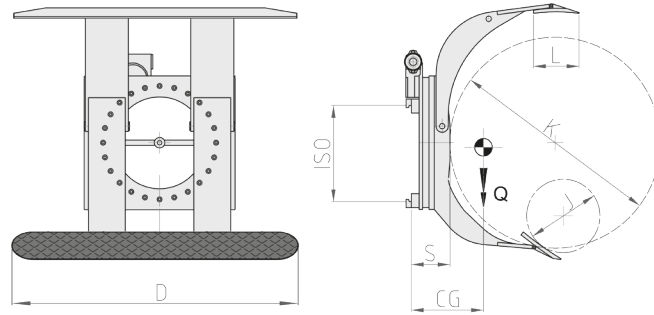

Hydraulic functions: 2 | Max working pressure: 175 Bar

Features:

- Clamping and rotation of more overlapping tyres of the same diameter.
- Short fixed arm or both adjustable arms (depending on the range of gripping diameters).
- 360° or 180° rotation with mechanical block.

Special Equipment:

- Custom made capacities/openings.
- Custom made Contact Pads.
- Rotating or Fixed Clamp with parallel arms with reduced dimensions for container loading/unloading operations.

Article	Attachment Capacity	ISO	Tyres Diameter		Contact Pads	Thickness	Centre of Gravity	Weight
			J (mm)	K (mm)				
N°	P (kg)	2328	J (mm)	K (mm)	DxL (mm)	S (mm)	CG (mm)	Q (kg)
21G042Q2C0002	1300	2	400	1300	1800x350	186	255	535
21G052Q2C0002	1300	2	250	1300	1800x350	186	235	520
21G002Q2C0023	1300	2	400	1300	2050x350	230	235	650
21G042Q2C0004	1300	2	400	1600	1800x350	186	305	585
21G052Q3C0001	1300	3	500	1600	1800x350	210	255	690
21G042Q3C0002	1400	3	500	1800	1800x350	210	260	915
21G00343C0005	2000	3	700	2000	1930x300	215	265	945

Oil flow rate

ISO	(L/min)	
	→ ←	↻
2	25	25
3	30	25

→||← Clamping
↻ Rotation

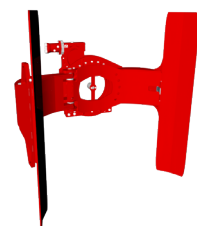

Please refer to our catalogue for further Special Equipment