

## 474.24.180 Box and Appliances Clamp with two pivoting arms

NEW ELECTRONIC CONTROL SYSTEM AVAILABLE

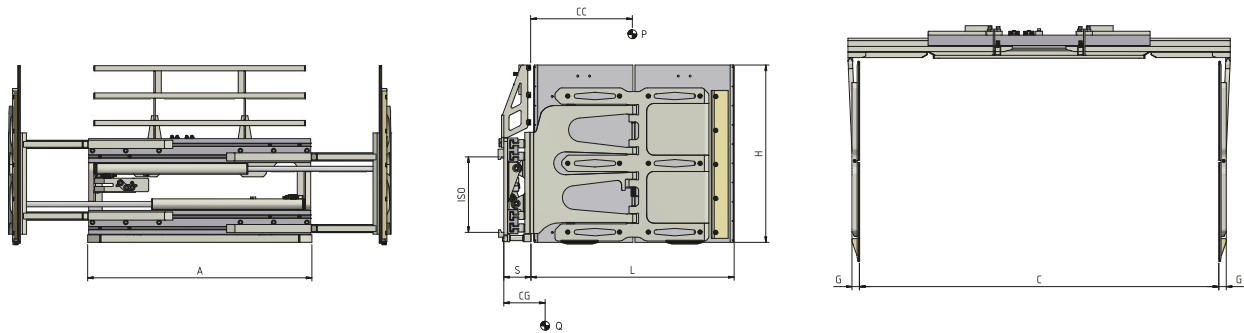

► Up to 24 Appliances or Cartons in one grab.

Hydraulic functions: 1 | Max working pressure: 175 Bar

### Features:

• Handling of Household Appliances and Cartons, arranged in double depth, on more rows/levels. • Pivoting rubber covered Arms. • Adjustable clamping force with hydraulic valve. • Pressure Relief Valve. • Non-return Valve. • Regenerative Valve. • Load backrest for clamps with arms exceeding 1000 mm in height.

### Special Equipment:

• Custom made widths/openings. • Custom made Arms. • Load backrest extensions and upper-blades restraint structures. • Single or double wing. • Mechanical block of the oscillation. • Sideshifting Valve or Semi-Integral Sideshift.

Article	Attachment Capacity	Load Centre of Gravity	ISO	Frame Width	Opening Range		Blades	Thickness	Centre of Gravity	Weight
N°	P (kg)	CC (mm)	2328	A (mm)	C Min (mm)	C Max (mm)	GxHxL (mm)	S (mm)	CG (mm)	Q (kg)
11L15D62A0004*	1500	675	2	1380	420	2040	51x1200x1350	188	448	865
11L15D62A0005*	1500	675	2	1550	460	2260	51x1200x1350	188	436	875
11L15D63A0006*	1900	675	3	1850	560	2760	51x1200x1350	188	407	920
11L15D63A0007*	1900	675	3	2000	460	2710	51x1200x1350	188	402	930
11L15D63A0008*	2000	675	3	2050	420	2680	51x1200x1350	188	401	950

\* Split Contact Pads and Load Backrest on blade

Oil flow rate	
ISO	(L/min)
	→  ←
2	20
3	25

→||← Clamping

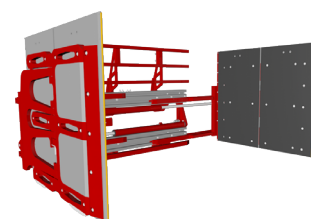

Please refer to our catalogue for further Special Equipment