

342 SM 360° Rotating Roll Clamp with 90° forward tipping and adjustable arms

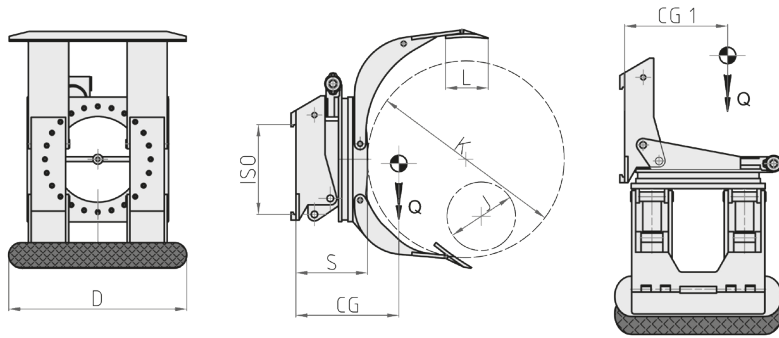

Hydraulic functions: 3 | Max working pressure: 175 Bar

Features:

- Clamping and rotation of one or more overlapping rolls of the same diameter.
- Short adjustable arm and long entire arm.
- 360° or 180° rotation with mechanical block.
- 90° frontal tipping to take rolls lying perpendicularly to the Forklift.



Special Equipment:

- Custom made capacities/openings.
- Custom made Contact Pads.
- Rotating or Fixed Clamp with parallel arms with reduced dimensions for container loading/unloading operations.

Article	Attachment Capacity	ISO	Rolls Diameter		Contact Pads	Thickness	Centre of Gravity	Centre of Gravity	Weight
N°	P (kg)	2328	J (mm)	K (mm)	DxL (mm)	S (mm)	CG (mm)	CG1 (mm)	Q (kg)
21J012G2C0001	900	2	250	1100	700x200	295	270	395	700
21J012G2C0002	900	2	250	1400	700x200	295	275	415	740
21J012Q2C0001	1300	2	250	1150	750x250	295	290	435	760
21J012Q2C0002	1300	2	250	1300	750x250	295	295	445	790
21J01342C0001	2000	2	250	1300	850x250	310	305	475	890
21J01343C0001	2000	3	250	1300	850x250	335	305	475	1080
21J01343C0002	2000	3	250	1600	850x250	335	310	495	1150
21J013G3C0001	2600	3	300	1300	900x250	370	315	505	1265
21J013G3C0002	2600	3	480	1600	900x250	370	325	535	1320
21J013Q3C0001	3000	3	250	1300	1015x300	380	330	530	1580
21J013W4C0001	3600	4	480	1800	1050x300	420	335	580	1920

Oil flow rate

ISO	(L/min)		
	→ ←	↻	↻
2	25	25	20
3	30	25	20
4	35	35	25

 Clamping
 Rotation
 Tipping

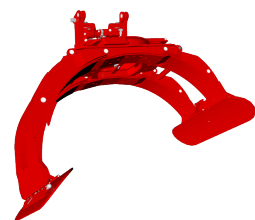

Please refer to our catalogue for further Special Equipment