

636 360° Rotating Drum Clamp for one Drum

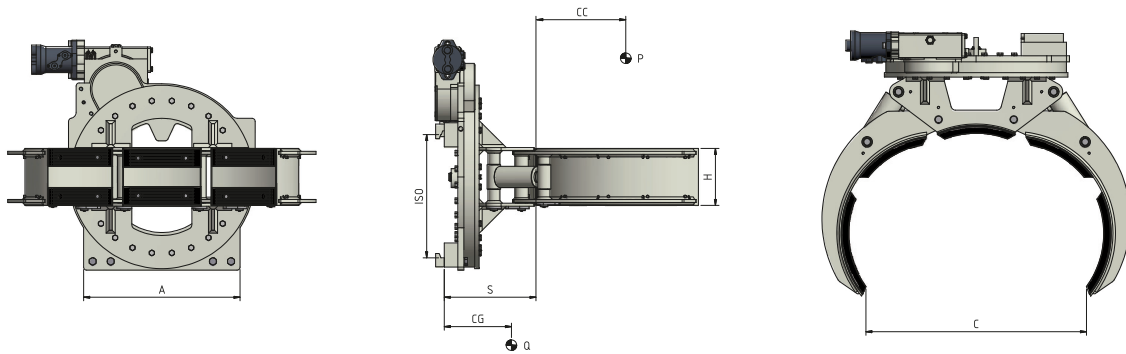

Hydraulic functions: 2 | Max working pressure: 175 Bar

Features:





- Clamping and rotation of a single drum. • Adjustable clamping force with hydraulic valve. • Pressure Relief Valve. • Non-return Valve. • Regenerative Valve.

Special Equipment:

- Custom made widths/openings. • Custom made Blades. • Load Backrest. • Semi-Integral Sideshift.

Article	Attachment Capacity	Load Centre of Gravity	ISO	Frame Width	Drums Diameter		Blades Height	Thickness	Centre of Gravity	Weight
N°	P (kg)	CC (mm)	2328	A (mm)	C Min (mm)	C Max (mm)	H (mm)	S (mm)	CG (mm)	Q (kg)
49H2C0001	300	335	2	800	600	700	190	315	153	240

 Oil flow rate

ISO	(L/min)		 Clamping  Rotation
			
2	20	20	

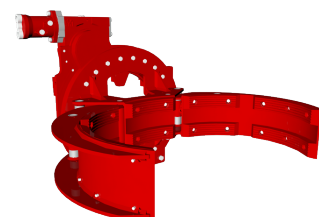

Please refer to our catalogue for further Special Equipment