

## 213 360° Box Rotator with upper restraint arm

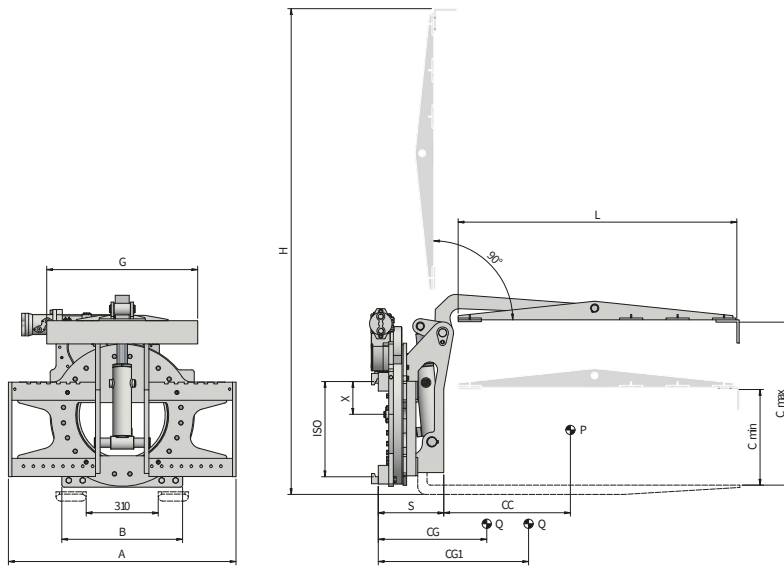

Hydraulic functions: 2 | Max working pressure: 175 Bar

### Features:

- Suitable for emptying boxes (bins) in any use (scrap, recycling, agricultural sector).
- Special box blocking system that can be actuated during rotation.

### Special Equipment:

- Special widths and/or strokes.
- Forks.
- Hooks with custom made strokes and dimensions.
- Load Backrest.

Article	Closed Attachment Capacity	Load Centre of Gravity	ISO	Carriage Width	Height	Minimum Fork Carriage	Rotation Centre	Box H From the Forks Level	Plate Dimension	Thickness	Centre of Gravity	Centre of Gravity	Weight
N°	P (kg)	CC (mm)	2328	A (mm)	H (mm)	B (mm)	X (mm)	C Min (mm) C Max (mm)	GxL (mm)	S (mm)	CG (mm)	CG1 (mm)	Q (kg)
25A342A0006	2500	500	2	980	1945	500	141	360 680	650x1175	320	175	245	275

### Accessories on request

SLS - Semi-Integral Sideshift (requires an additional hydraulic function)

Oil flow rate		
ISO	(L/min)	
	↻	↑↓
2	25	25

↻ Rotation  
 ↑↓ Vertical Opening/Closing

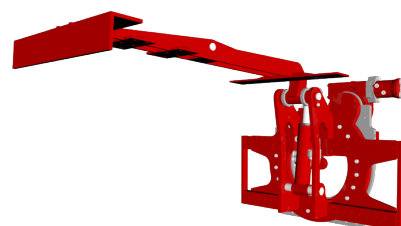

Please refer to our catalogue for further Special Equipment