

30I.474.I90 360° Rotating Drum Clamp for two or four Drums

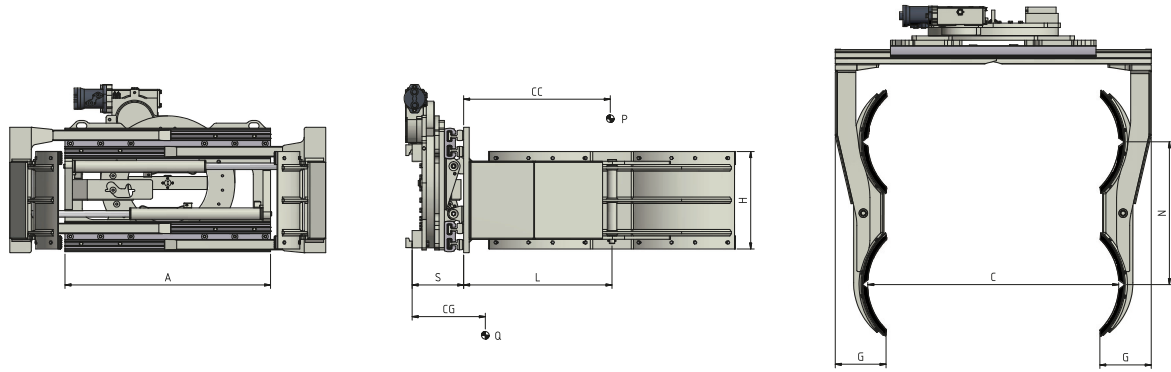

Hydraulic functions: 2 | Max working pressure: 175 Bar

Features:





- Clamping and rotation of 2 or 4 Drums at once. • Adjustable clamping force with hydraulic valve. • Pressure Relief Valve. • Non-return Valve. • Regenerative Valve.

Special Equipment:

- Custom made widths/openings. • Custom made Blades. • Load Backrest. • "V" shaped Plates for gripping drums with different diameters. • Sideshifting Valve or Semi-Integral Sideshift.

Article	Attachment Capacity	Load Centre of Gravity	ISO	Frame Width	Opening Range		Blades	Distance	Thickness	Centre of Gravity	Weight
N°	P (kg)	CC (mm)	2328	A (mm)	C Min (mm)	C Max (mm)	GxHxL (mm)	H (mm)	S (mm)	CG (mm)	Q (kg)
11M24AQ2A0001	1200	670	2	950	340	1340	236x450x690	660	234	371	442
11M24D62A0001	1900	675	2	1050	270	1520	238x450x700	660	267	305	700

 Oil flow rate

ISO	(L/min)		 Clamping  Rotation
			
2	25	20	

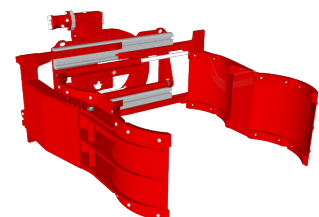

Please refer to our catalogue for further Special Equipment