

505i Fork mounted Push-Pull with Sheet Retention

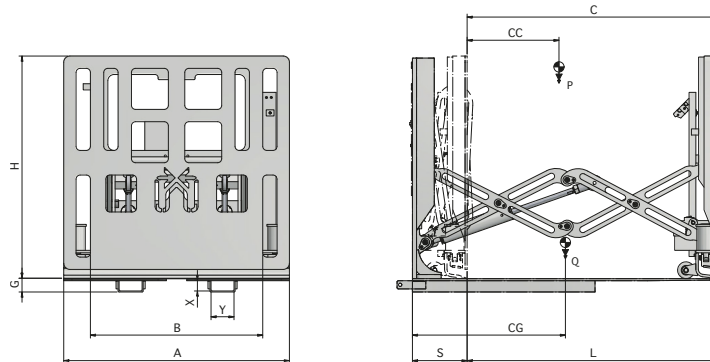

Hydraulic functions: 1 + Electrical functions: 1 | Max working pressure: 175 Bar

Features:

- Fork mounted attachment.
- Handling of non-palletized goods.
- Allows to recover sheets of paper, cardboard, or plastic.
- The elimination of the pallet reduces the packing costs and the encumbrances in the warehouses, and increases the volume of the transportable goods.

Special Equipment:

- Custom made capacities/strokes.
- Models with no Sheet Retention are available.

Article	Attachment Capacity	Load Centre of Gravity	Forks Mounting Section	Stroke	Height	Load Platform			Thickness	Centre of Gravity	Weight
N°	P (kg)	CC (mm)	Y+X (mm)	C (mm)	H (mm)	A (mm)	L (mm)	G (mm)	S (mm)	CG (mm)	Q (kg)
33B2J6D0001	1000	550	117x45	1120	1000	1200	1070	55	270	235	585
33B2J6D0002	1000	650	117x45	1270	1100	1200	1220	55	270	245	650
33B2U6D0001	1500	550	142x45	1120	1000	1250	1070	55	275	240	690
33B2U6D0002	1500	650	142x45	1270	1100	1250	1220	55	275	250	760
33B346D0001	2000	550	142x45	1120	1000	1250	1070	70	300	270	790
33B346D0002	2000	650	142x45	1270	1100	1250	1220	70	300	280	890

Oil flow rate		
P (Kg)	(L/min)	
	↕	↔
1000 - 1500	15	10
2000	20	15

↕ Opening
↔ Closing
↔ Clamping

Please refer to our catalogue for further Special Equipment