

917.T2 Double Fork Positioner with Semi-Integral Sideshift (1-2 Pallets)

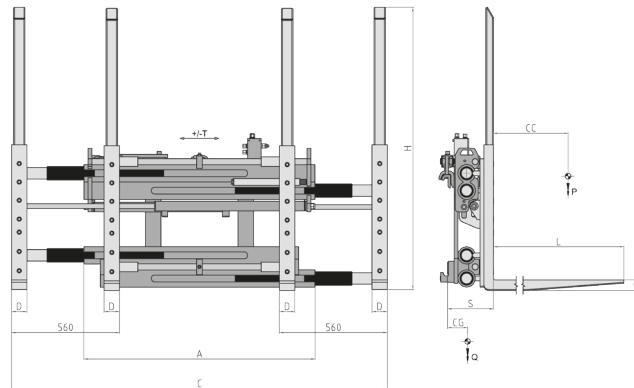

Hydraulic functions: 2 | Max working pressure: 200 Bar

Features:

- One or two pallets side by side.
- Smaller frame ease dimension.
- 4 bolt-on forks supplied with reinforced heel and load backrest, for easier replacement operations.
- Easier and safer manoeuvres, even in narrow spaces.

Special Equipment:

- Special widths and/or strokes.
- Custom made Forks.
- Custom made Load Backrest.
- Load Stabiliser with custom made dimensions/openings.

Article	Attachment Capacity	Load Centre of Gravity	ISO	Carriage Width	Opening Range		Forks	Forks Height	Stroke	Thickness	Centre of Gravity	Weight
N°	P (kg)	CC (mm)	2328	A (mm)	C Min (mm)	C Max (mm)	DxGxL (mm)	H (mm)	T (mm)	S (mm)	CG (mm)	Q (kg)
15REA2A1004	2200	600	2a	1200	560	1940	80x40x1150	1460	± 100	224	205	480
15RFB2A1005	2500	600	2a	1200	560	1940	80x50x1150	1460	± 100	234	220	550
15RFB3A1005	2600	600	3a	1200	560	1940	80x50x1150	1460	± 100	234	210	550
15RHF3A1005	3200	600	3a	1200	560	1940	80x60x1150	1460	± 100	254	220	635
15RV3A1003	4000	600	3a	1400	560	1940	80x60x1150	1460	± 100	254	195	650

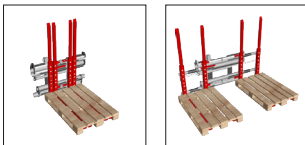

Oil flow rate		
ISO	(L/min)	
	↔	↕
2	15	45
3	15	45

- ↔ Shifting
- ↕ Opening
- ↕ Closing

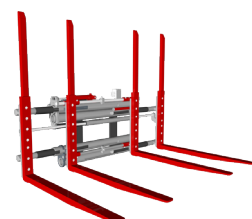

Please refer to our catalogue for further Special Equipment