

575 Fork Positioner

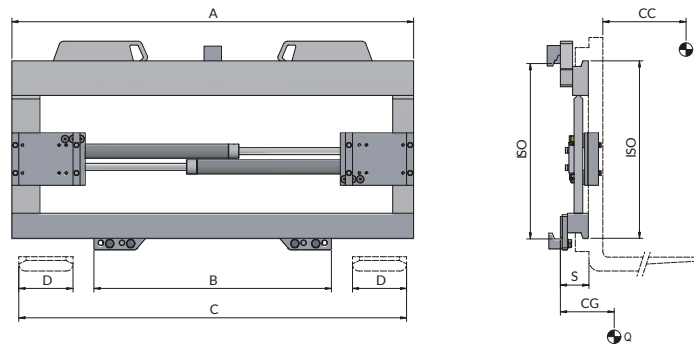

Hydraulic functions: 1 | Max working pressure: 110 Bar

Features:

- Moving housing Cylinders System (ATIB Material Handling Patented) for a constant and synchronised movement of the forks.
- Fast and accurate lifting and positioning of loads.
- Pressure Relief Valve.
- Recommended use of forks with max length 1500 mm.
- Adjustable plates for use of forks with different sections.
- Reduced damage to pallets and goods.
- Easier manoeuvres even in narrow spaces.

Special Equipment:

- Special widths and/or openings.
- Standard Forks.
- Load Backrest.

Article	Attachment Capacity	Load Centre of Gravity	ISO	Carriage Width	Minimum Fork Carriage	Opening Range		Fork Width	Thickness	Centre of Gravity	Weight
N°	P (kg)	CC (mm)	2328	A (mm)	B (mm)	C Min (mm)	C Max (mm)	D (mm)	S (mm)	CG (mm)	Q (kg)
18LFA2C0021	2500	500	2	970	720	340	920	130	70	37	88
18LFA2C0022	2500	500	2	1040	720	340	990	130	70	38	93
18LFA2C0023	2500	500	2	1150	720	340	1100	130	70	40	99
18LLL3C0011	5000	500	3	1150	860	380	1100	150	80	44	141
18LLL3C0013	5000	500	3	1250	860	380	1200	150	80	45	150
18LLL3C0014	5000	500	3	1350	860	380	1300	150	80	46	160

Oil flow rate	
ISO	(L/min)
	↑ ↓
2	5
3	5

↑ ↓ Opening Closing

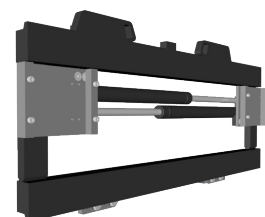

Please refer to our catalogue for further Special Equipment