

209 Hook on Sideshift ISO2

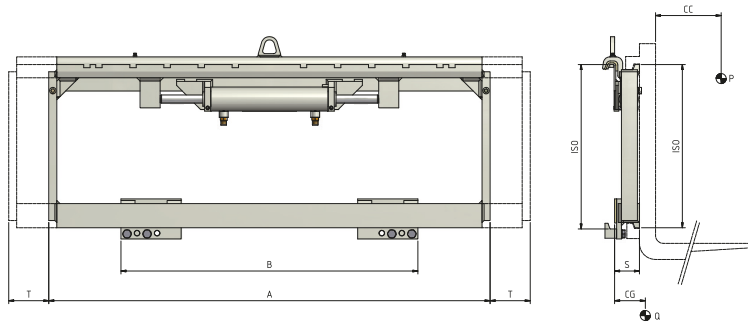

Hydraulic functions: 1 | Max working pressure: 200 Bar

Features:

- Sturdy and long lasting design. • Transverse load displacement. • Fast and accurate lifting and positioning of loads. • Lower risk of damage to goods and pallets.
- Easier manoeuvres, even in confined spaces.

Special Equipment:

- Special widths and/or strokes. • Custom made Forks. • Custom made Load Backrest.

Article	Attachment Capacity	Load Centre of Gravity	ISO	Carriage Width	Minimum Fork Carriage	Stroke	Thickness	Centre of Gravity	Weight
N°	P (kg)	CC (mm)	2328	A (mm)	B (mm)	T (mm)	S (mm)	CG (mm)	Q (kg)
03LFA2C3001	2500	500	2	920	860	± 100	63	34	48
03LFA2C3008	2500	500	2	970	910	± 100	63	35	49
03LFA2C3003	2500	500	2	1000	940	± 100	63	36	50
03LFA2C3004	2500	500	2	1020	960	± 100	63	36	51
03LFA2C3005	2500	500	2	1040	980	± 100	63	36	52
03LFA2C3006	2500	500	2	1100	1040	± 100	63	37	55
03LFA2C3007	2500	500	2	1150	1090	± 100	63	38	57

Oil flow rate

ISO	(L/min)
2	10

↔ Shifting

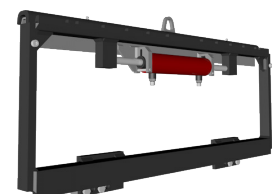

Please refer to our catalogue for further Special Equipment