

917.T2 Double Fork Positioner with Semi-Integral Sideshift (1-2 Pallets)

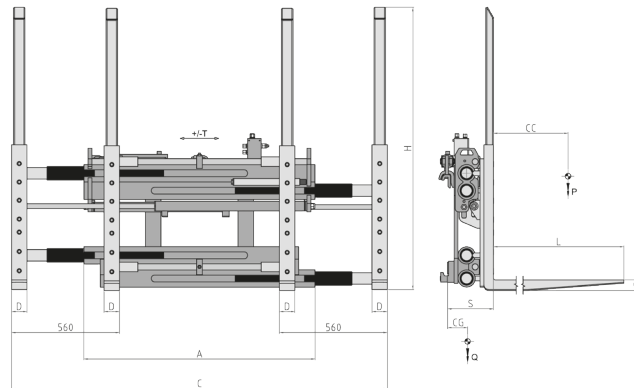

HYDRAULIC FUNCTIONS: 2 | MAX WORKING PRESSURE: 200 Bar

Features:

- One or two pallets side by side.
- Smaller frame ease dimension.
- 4 bolt-on forks supplied with reinforced heel and load backrest, for easier replacement operations.
- Easier and safer manoeuvres, even in narrow spaces.

Special Equipment:

- Special widths and/or strokes.
- Custom made Forks.
- Custom made Load Backrest.
- Load Stabiliser with custom made dimensions/openings.

ART. N°	P (Kg)	CC (mm)	ISO 2328	A (mm)	C (mm)		DxGxL (mm)	H (mm)	T (mm)	S (mm)	CG (mm)	Q (Kg)
					Min (mm)	Max (mm)						
15REA2A1004	2200	600	II	1200	560	1940	80x40x1150	1460	± 100	224	205	480
15RFB2A1005	2500	600	II	1200	560	1940	80x50x1150	1460	± 100	234	220	550
15RFB3A1005	2600	600	III	1200	560	1940	80x50x1150	1460	± 100	234	210	550
15RHF3A1005	3200	600	III	1200	560	1940	80x60x1150	1460	± 100	254	220	635
15RJV3A1003	4000	600	III	1400	560	1940	80x60x1150	1460	± 100	254	195	650

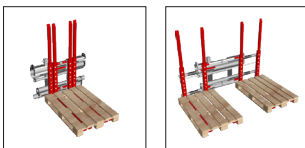

OIL FLOW RATE

ISO	(L/min)	
	↔	↕
II	15	45
III	15	45

↕ Shifting
 ↕ Opening
 ↕ Closing

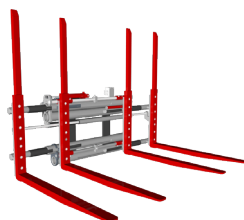

P ATTACHMENT CAPACITY
CC LOAD CENTRE OF GRAVITY
A CARRIAGE WIDTH
C OPENING RANGE
DxGxL FORKS
H FORKS HEIGHT
T STROKE
S THICKNESS
CG CENTRE OF GRAVITY
Q WEIGHT

Please refer to our catalogue for further Special Equipment