

## 971 Fork mounted Hydraulic Bucket

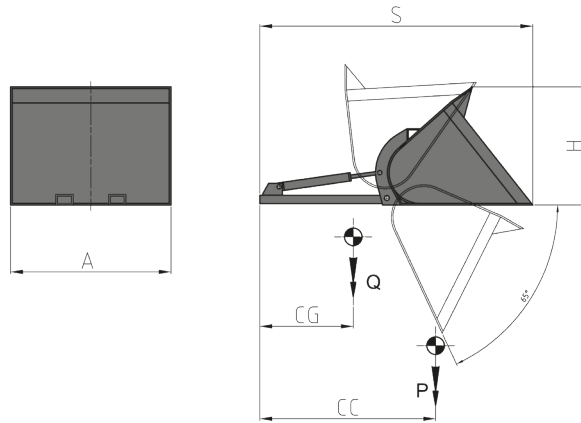

HYDRAULIC FUNCTIONS: 1 | MAX WORKING PRESSURE: 175 Bar

### Features:

- Fork mounted attachment.
- Materials loading/unloading operations for Building Industry (sand, gravel, concrete, terrain).
- Can also be used in Agriculture.
- Suitable for occasional/seasonal work.

ART. N°	P (Kg)	CC (mm)	PC (m <sup>2</sup> )	A (mm)	H (mm)	S (mm)	CG (mm)	Q (Kg)
41D086D002	930	950	0.52	1000	799	2075	820	280
41D0A6D002	1110	950	0.62	1200	799	2075	850	300
41D0D6D003	1310	950	0.73	1400	799	2075	880	400
41D0E6D001	1530	980	0.85	1200	952	2330	890	430
41D0J6D001	1760	980	0.98	1400	952	2330	930	460
41D0K6D001	2010	980	1.12	1600	952	2330	960	490

### OIL FLOW RATE

(L/min)
20

Tipping

**P** ATTACHMENT CAPACITY  
**CC** LOAD CENTRE OF GRAVITY  
**PC** LOAD CAPACITY  
**A/H** BUCKET DIMENSIONS  
**S** THICKNESS  
**CG** CENTRE OF GRAVITY  
**P** WEIGHT

Please refer to our catalogue for further Special Equipment