

636 360° Rotating Drum Clamp for one Drum

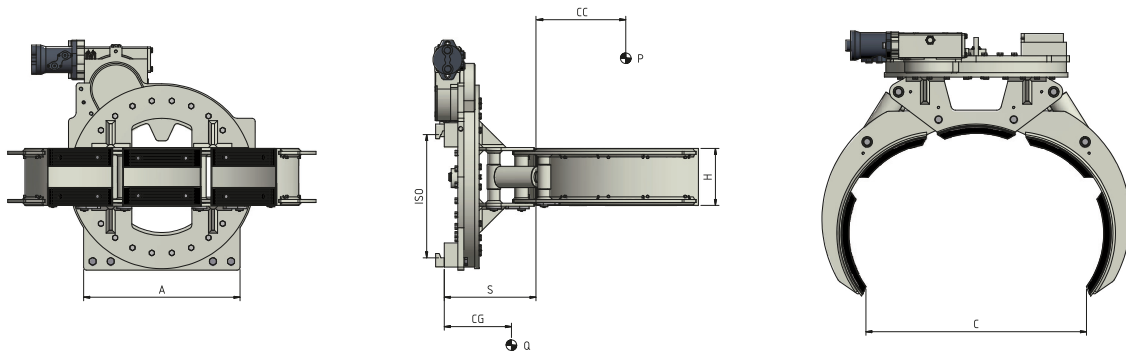

HYDRAULIC FUNCTIONS: 2 | MAX WORKING PRESSURE: 175 Bar

Features:

- Clamping and rotation of a single drum.
- Adjustable clamping force with hydraulic valve.
- Pressure Relief Valve.
- Non-return Valve.
- Regenerative Valve.

Special Equipment:

- Custom made widths/openings.
- Custom made Blades.
- Load Backrest.
- Semi-Integral Sideshift.

ART. N°	P (Kg)	CC (mm)	ISO 2328	A (mm)	C		H (mm)	S (mm)	CG (mm)	Q (Kg)
					Min (mm)	Max (mm)				
49H2C0001	300	335	II	800	600	700	190	315	153	240

OIL FLOW RATE

ISO	(L/min)	
	→ ←	↻
II	20	20

→||← Clamping
↻ Rotation

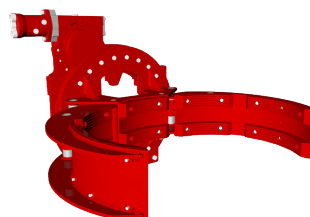

P ATTACHMENT CAPACITY
CC LOAD CENTRE OF GRAVITY
A FRAME WIDTH
C DRUMS DIAMETER
H BLADES HEIGHT
S THICKNESS
CG CENTRE OF GRAVITY
Q WEIGHT

Please refer to our catalogue for further Special Equipment