

301.474.160 360° Rotating Drum Clamp for one or two Drums

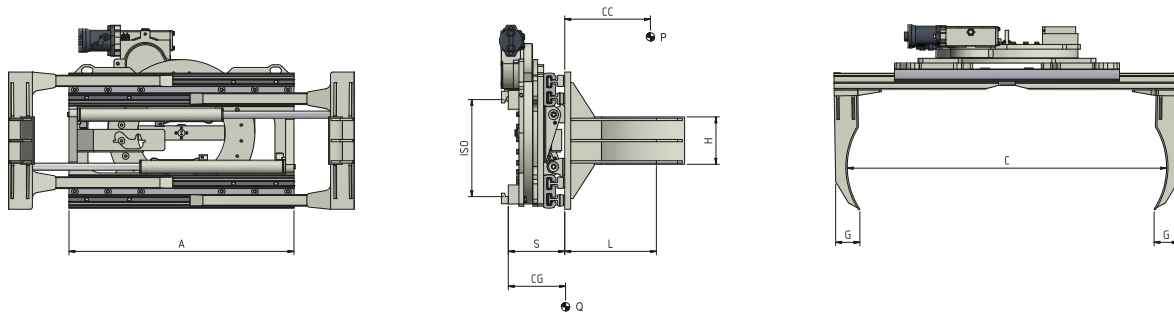

HYDRAULIC FUNCTIONS: 2 | MAX WORKING PRESSURE: 175 Bar

Features:

- Clamping and rotation of 1 or 2 Drums at once.
- Adjustable clamping force with hydraulic valve.
- Pressure Relief Valve.
- Non-return Valve.
- Regenerative Valve.

Special Equipment:

- Custom made widths/openings.
- Custom made Blades.
- Load Backrest.
- "V" shaped Plates for gripping drums with different diameters.
- Sideshifting Valve or Semi-Integral Sideshift.

ART. N°	P (Kg)	CC (mm)	ISO 2328	A (mm)	C		GxHxL (mm)	S (mm)	CG (mm)	Q (Kg)
					Min (mm)	Max (mm)				
11M23AQ2A0001	1200	330	II	950	490	1730	100x200x330	234	132	390
11M23BE2A0001	1400	330	II	950	450	1600	100x200x330	267	146	476

OIL FLOW RATE

ISO	(L/min)	
	→ ←	↻
II	25	20

→||← Clamping
↻ Rotation

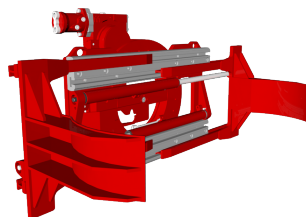

P ATTACHMENT CAPACITY
CC LOAD CENTRE OF GRAVITY
A FRAME WIDTH
C OPENING RANGE
GxHxL BLADES
S THICKNESS
CG CENTRE OF GRAVITY
Q WEIGHT

Please refer to our catalogue for further Special Equipment