

575 Fork Positioner

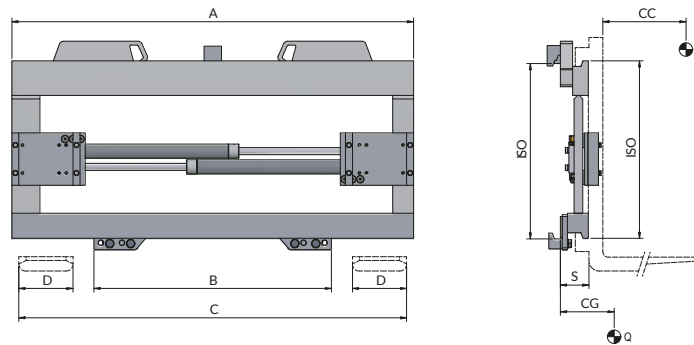

HYDRAULIC FUNCTIONS: 1 | MAX WORKING PRESSURE: 110 Bar

Features :

- Moving housing Cylinders System (ATIB Patented) for constant and synchronised fork movement.
- Fast and accurate lifting and positioning of loads.
- Pressure Relief Valve.
- Recommended use of forks with max length 1500 mm.
- Adjustable plates for use of forks with different sections.
- Reduced damage to pallets and goods.
- Easier maneuvers even in narrow spaces.

Special Equipment:

- Special widths and/or openings.
- Standard Forks.
- Load Backrest.

ART. N°	P (Kg)	CC (mm)	ISO 2328	A (mm)	B (mm)	C		D (mm)	S (mm)	CG (mm)	Q (Kg)
						Min (mm)	Max (mm)				
18LFA2C0021	2500	500	II	970	720	340	920	130	70	37	88
18LFA2C0022	2500	500	II	1040	720	340	990	130	70	38	93
18LFA2C0023	2500	500	II	1150	720	340	1100	130	70	40	99
18LLL3C0011	5000	500	III	1150	860	380	1100	150	80	44	141
18LLL3C0013	5000	500	III	1250	860	380	1200	150	80	45	150
18LLL3C0014	5000	500	III	1350	860	380	1300	150	80	46	160

OIL FLOW RATE

ISO	(L/min)
II	5
III	5

↑ Opening
↓ Closing

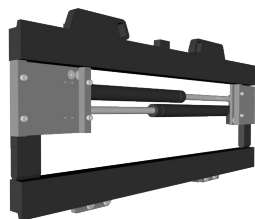

- P ATTACHMENT CAPACITY
- CC LOAD CENTER OF GRAVITY
- A CARRIAGE WIDTH
- B MINIMUM FORK CARRIAGE
- C OPENING RANGE
- D FORK WIDTH
- S THICKNESS
- CG CENTER OF GRAVITY
- Q WEIGHT

Please refer to our catalogue for further Special Equipment