

Fork Positioners

Fork Positioner realized with the exclusive “Moving Housing System” (A.T.I.B. Patented) that guarantees a constant and synchronized movement of the forks. It's completely made of Aluminum and that makes it perfect for food, chemical and pharmaceutical industry. We suggest not to mount forks over 1500 mm long. Adjustable plates allow to use forks with different sections size.

476 FORK POSITIONER WITH INTEGRAL SIDESHIFT



PATENTED

REFERENCE	CAPACITY (P) Kg	LOAD CENTRE (CC) mm	ISO 2328 - FEM	CARRIAGE WIDTH (A) mm	OPENING RANGE		FORK WIDTH (D) mm	STROKE (T) mm	THICKNESS (S) mm	CENTER OF GRAVITY (CG) mm	WEIGHT (Q) Kg
					(C MIN) mm	(C MAX) mm					
18EFA2C2001	2500	500	II	920	350	880	130	100	61	30	34
18EFA2C2002	2500	500	II	970	350	930	130	100	61	30	36
18EFA2C2005	2500	500	II	1040	350	1000	130	100	61	31	39
18EFA2C2006	2500	500	II	1100	350	1060	130	100	61	32	41
18EFA2C2007	2500	500	II	1150	350	1110	130	100	61	32	44
18ELL3C2001	5000	500	III	1020	350	940	150	100	70	31	57
18ELL3C2002	5000	500	III	1070	350	990	150	100	70	32	59
18ELL3C2003	5000	500	III	1150	350	1070	150	100	70	33	60
18ELL3C2004	5000	500	III	1170	350	1090	150	100	70	33	61
18ELL3C2005	5000	500	III	1250	350	1170	150	100	70	35	64
18ELL3C2006	5000	500	III	1350	350	1270	150	100	70	37	66

Hydraulic functions required: 2 | Maximum working pressure: 110 bar

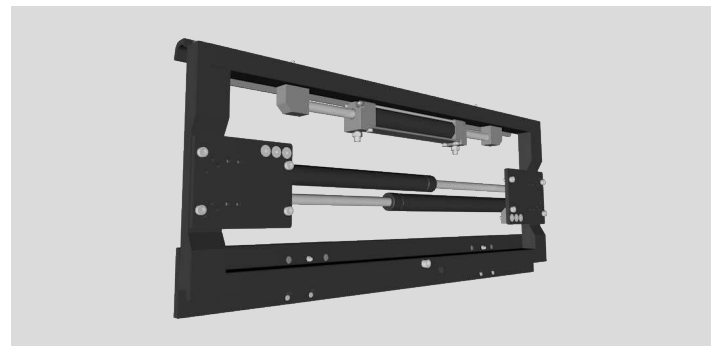
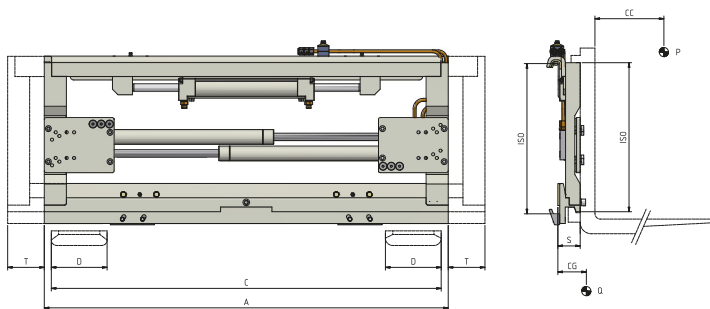

OPTIONS

- Pipes and Fitting Kit.
- Quick Release Hoses couplings Kit.
- Pressure Gauge.
- Bronze Wear Pads.
- Quick Release Hooks.
- Drilling for Load Backrest.
- Solenoid Valve two Functions with Electric Kit (specify voltage).
- Check Valve for Barrel Grabbing.
- Automatic Greasing System for Semi-Integral Sideshift.

ADDITIONAL EQUIPMENT ON REQUEST

- Special width and/or stroke.
- Forks with any section and lenght.
- Load Backrest of various widths and heights.

OIL FLOW RATE

TYPE	ISO 2328 - FEM	MIN CAPACITY (L/min)	MAX CAPACITY (L/min)	RECOMMENDED CAPACITY (L/min)
476	ISO 2	5	15	10
476	ISO 3	10	20	15

- A - Pin-Type Forks
- B - Bolted Forks
- C - Welded Forks
- D - Telescopic Forks

