

Fork Positioners

Fork Positioner that guarantees a constant and synchronized movement of the forks thanks to differentiated cylinders and it can be integrated into the mast, replacing the original fork carriage, reducing the thickness and increasing at the same time the forklift residual capacity. Models with FEM forks connections, welded forks, bolt-on forks, without sideshift or with check valve for barrel grabbing are available.

678 INTEGRATED FORK POSITIONER WITH INTEGRAL SIDESHIFT

REFERENCE	CAPACITY (P) Kg	LOAD CENTRE (CC) mm	ISO 2328 - FEM	CARRIAGE WIDTH (A) mm	OPENING RANGE (C MIN) mm (C MAX) mm		FORKS WIDTH (D) mm	STROKE (T) mm	THICKNESS (S) mm	CENTER OF GRAVITY (CG) mm	WEIGHT (Q) Kg
17UFA2A2001	2500	500	II	980	490	1120	130	100	134	65	195
17UFA2A2002	2500	500	II	1040	490	1180	130	100	134	65	200
17UFA2A2003	2500	500	II	1100	490	1240	130	100	134	66	210
17UFA2A2005	2500	500	II	1150	490	1290	130	100	134	66	217
17UFA2A2006	2500	500	II	1350	490	1490	130	100	134	67	242
17UH23A2001	3000	500	III	1150	490	1290	130	100	145	70	225
17UH23A2002	3000	500	III	1350	490	1490	130	100	145	71	260
17UH23A2003	3000	500	III	1550	490	1690	130	100	145	72	285
17UH23A2004	3000	500	III	1650	490	1790	130	100	145	72	300
17ULL3A2004	5000	500	III	1150	490	1290	150	100	170	79	335
17ULL3A2001	5000	500	III	1350	490	1490	150	100	170	80	360
17ULL3A2002	5000	500	III	1550	490	1690	150	100	170	81	395
17ULL3A2003	5000	500	III	1650	490	1790	150	100	170	82	410

Hydraulic functions required: 2 | Maximum working pressure: 80 bar

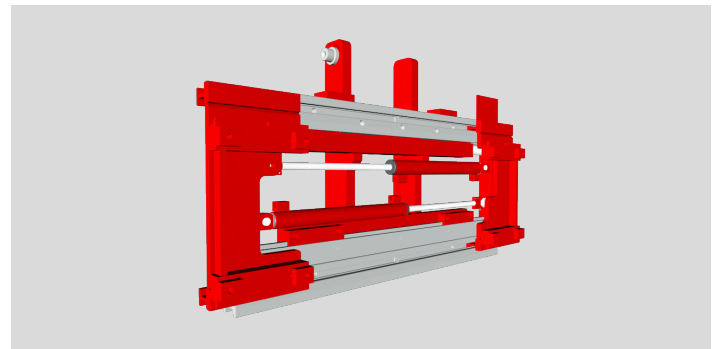
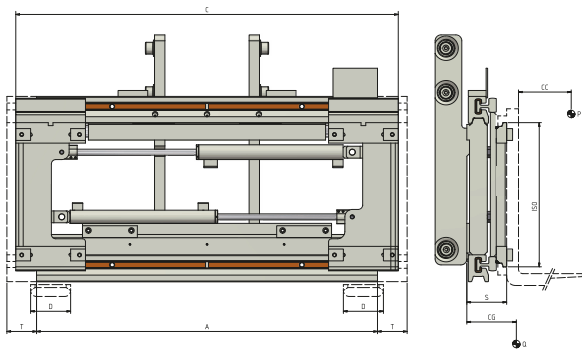

OPTIONS

- Pipes and Fitting Kit.
- Quick Release Hoses couplings Kit.
- Pressure Gauge.
- Bronze Wear Pads.
- Quick Release Hooks.
- Drilling for Load Backrest.
- Solenoid Valve two Functions with Electric Kit (specify voltage).
- Pressure Relief Valve supplied as standard.
- Check Valve for Barrel Grabbing.
- Automatic Greasing System for Semi-Integral Sideshift.

ADDITIONAL EQUIPMENT ON REQUEST

- Forks Positioners with special width and/or stroke.
- Forks with any section and lenght.
- Load Backrest of various widths and heights.
- FEM Hook without Sideshift, Welded Forks, Bolted Forks or Telescopic Forks.

OIL FLOW RATE

In **bold** the values referred to the sideshift capacities.

TYPE	ISO 2328 - FEM	MIN CAPACITY (L/min)	MAX CAPACITY (L/min)	RECOMMENDED CAPACITY (L/min)
678	ISO 2	10/5	20/15	15/10
678	ISO 3 - 17UH2	15/5	25/15	20/10

- A - Pin-Type Forks
- B - Bolted Forks
- C - Welded Forks
- D - Telescopic Forks

