

Clamps

Clamp with rubber covered arms, suggested to customers who need to move appliances and cardboards settled in double depth, on multiple rows and layers (they can handle up to 12 domestic appliances or cardboards in one grab). The clamping force, which can be set through hydraulic valve, allows a safe movement of the load. A pressure relief valve, a non-return valve and a regenerative valve are supplied as standard on each model. Min. and Max. openings can be adapted to different needs, as arms dimension and length. Side shifting valve and semi-integral sideshift available on request.

474.181 BOX AND APPLIANCES CLAMP WITH FIXED ARMS

REFERENCE	ATTACHMENT CAPACITY (P) Kg	LOAD CENTRE (CC) mm	ISO 2328 FEM	FRAME WIDTH (A) mm	OPENING RANGE (C MIN) mm (C MAX) mm		BLADES DIMENSIONS (GxHxL) mm	THICKNESS (S) mm	CENTER OF GRAVITY (CG) mm	WEIGHT (Q) Kg
11L14AQ2A0001	1200	500	II	950	580	1820	30X600X650	134	188	320
11L14AQ2A0002	1200	500	II	950	580	1820	30X700X650	134	201	335
11L14AQ2A0003	1200	500	II	950	580	1820	30X600X750	134	220	335
11L14AQ2A0004	1200	500	II	950	580	1820	30X700X750	134	234	350
11L14AQ2A0005	1200	500	II	950	580	1820	30X600X850	134	253	355
11L14AQ2A0006	1200	500	II	950	580	1820	30X700X850	134	268	370
11L14BE2A0001	1400	500	II	1050	590	1940	30X600X650	162	188	455
11L14BE2A0002	1400	500	II	1050	590	1940	30X700X650	162	201	477
11L14BE2A0003	1400	500	II	1050	590	1940	30X600X750	162	218	470
11L14BE2A0004	1400	500	II	1050	590	1940	30X700X750	162	232	494
11L14BE2A0005	1400	500	II	1050	590	1940	30X600X850	162	250	498
11L14BE2A0006	1400	500	II	1050	590	1940	30X700X850	162	266	516

Hydraulic functions required: 1 | Maximum working pressure: 175 bar

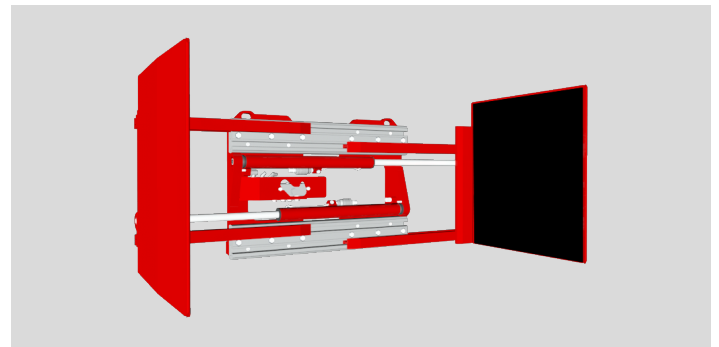
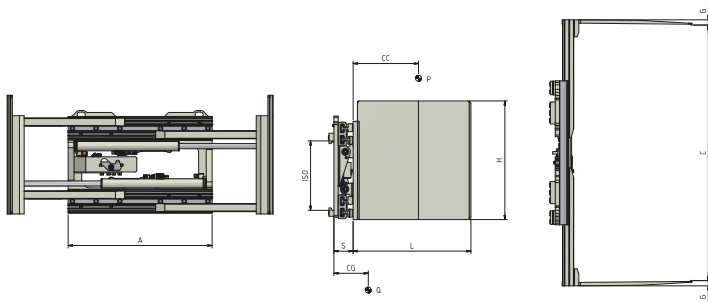

OPTIONS

- Pipes and Fitting Kit.
- Quick Release Hoses couplings Kit.
- Pressure Gauge.
- Bronze Wear Pads.
- Quick Release Hooks.
- Solenoid Valve two Functions with Electric Kit (specify voltage).
- Pressure Relief Valve, Non-Return Valve, Regenerative Valve.
- 3 Position Pressure Relief Valve.
- Manual Pressure-Relief Panel with Pressure Gauge and Indicator Lamp.
- Electronic Pressure-Relief Panel with Keyboard and Indicator Lamp.
- Automatic Pressure-Relief System.
- Sideshifting Valve.
- Semi-Integral Sideshift.
- Automatic Greasing System for Semi-Integral Sideshift.

- Preparation of Clamp for quick Change Arms (up to/over 3500 Kg).
- Preparation of quick Change Arms (up to/over 3500 Kg capacity).
- Cylinder Protection Plate.
- Wear-free Plates under the Frame.
- Wear-free Plates under the Blades.

ADDITIONAL EQUIPMENT ON REQUEST

- Clamps with special width and/or stroke.
- Load Backrest of various widths and heights.
- Blades of any length and height.

OIL FLOW RATE

TYPE	ISO 2328 - FEM	MIN CAPACITY (L/min)	MAX CAPACITY (L/min)	RECOMMENDED CAPACITY (L/min)
474.181	ISO 2	10	40	20

